

Fact Sheet

PackSecure

BIZERBA

Complete optical control of packages: With PackSecure you meet key criteria for an optimal product quality – n undamaged seal and correct labeling. The system completely checks each product side for any damaged seals, incorrect labels or information. Packages which do not meet the defined criteria are automatically rejected.



More information
High performance with a wide range of solutions and options.

Specifications	Facts	Details
Functions	<p>Detects</p> <ul style="list-style-type: none"> – Contaminations/foreign bodies in the seal on trays, flow packs and cups – Poor seal quality <p>Checking of presence, position and orientation of labels</p> <p>Reads information such as characters and codes on any side of the package</p> <ul style="list-style-type: none"> – top – bottom – side <p>Checks lateral label: presence and reading of label number</p> <p>Checks matching of labels</p>	<p>Contaminations/foreign bodies from 1 mm²</p> <p>Air bubbles, wrinkles in the top film</p> <p>Independent of printing technology (ink-jet, thermal transfer, laser)</p> <p>Checks lateral label: presence and reading of label number</p>
Integration	<p>All these functions are efficiently fulfilled by one compact machine for an easy end-of-line integration.</p> <p>Before case packing, the stand-alone inspection machine detects defective packs and is able to reject them.</p>	
Versions	<p>basic</p> <p>pro</p>	<p>Detects contamination in the seal and checks labeling</p> <p>Detects contaminated and poor-quality sealing and checks labeling</p>
Camera system	<p>Two to four sensors used to check the seal for foreign body and/or the seal quality as well as the labeling</p> <p>Line scan camera</p> <p>Protected against ambient light and manipulations</p>	<p>Sensor consists of camera, lighting, and accessories. The quantity depends on the number of sides to be checked.</p> <p>The image recording field adjusts to the size of the products to be inspected. Life of LED lighting is more than 5 years.</p> <p>The pixel size (0.10 to 0.16 mm²) allows detection as from one square millimeter.</p> <p>No external influences on the inspection results</p>
Dimensions	<p>910 - 1,380 mm x 1,016 mm x 1,645 - 1,965 mm (L x W x H)</p>	<p>Device dimensions without rejection unit</p> <p>Width is 1,136 mm with cooling device</p>
Housing	<p>Design according to hygiene requirements</p>	<p>– EHEDG certified components</p>

		<ul style="list-style-type: none"> – Inclined surfaces for drainage of washing water – No risk of glass splinters according to the HACCP directive
IP rating	IP65	All optical inspection components are integrated in a tightly sealed stainless steel housing.
Max. conveying speed	60 m/min.	
Processing system	Industrial PC	<ul style="list-style-type: none"> – Operating system: Windows IoT Standard 10 – Processor Intel® Core™ i7 – Real time image processing card
Interfaces	USB ETHERNET	Connection to customer network via Ethernet (TCP/IP possible)
Power supply	230 VAC; 50 Hz / 110 VAC, 60 Hz (incl. transformer) + single phase + ground uninterruptible power supply (UPS) system for computing and display units	Open to other local voltage with a transformer
Ambient temperature	1 °C to 35 °C	With cooling device as from 15 °C
Humidity	Max. 85%, non-condensing	
Maintenance	Tool-free dismantling of conveyor belts in less than one minute	
Optical signaling device	Signal lamp	Visual alarm for detection of non-conforming package
Conveying direction	left to right right to left	
By-pass mode	Switch activated with a key	Allows continuous production even in case of an operating system failure
Options	Facts	Details
Checks	<p>Checking of product presence in a package</p> <p>Appearance and arrangement of the products in the packaging</p>	Other inspections based on feasibility upon request
Production control	Communication interface to the process	<p>Data transfer within the factory concerning:</p> <ul style="list-style-type: none"> – System performance (monitoring of the device cycle, process data etc.) – Production monitoring (history of batch changes, test statistics, archiving of batch changes)
Rejection unit	Mechanical pusher	
IP rating	IP66 upgrade	<ul style="list-style-type: none"> – Buttons – Emergency stop switch – Display
US-Special current transformer	115 V AC	

Dimensional drawings

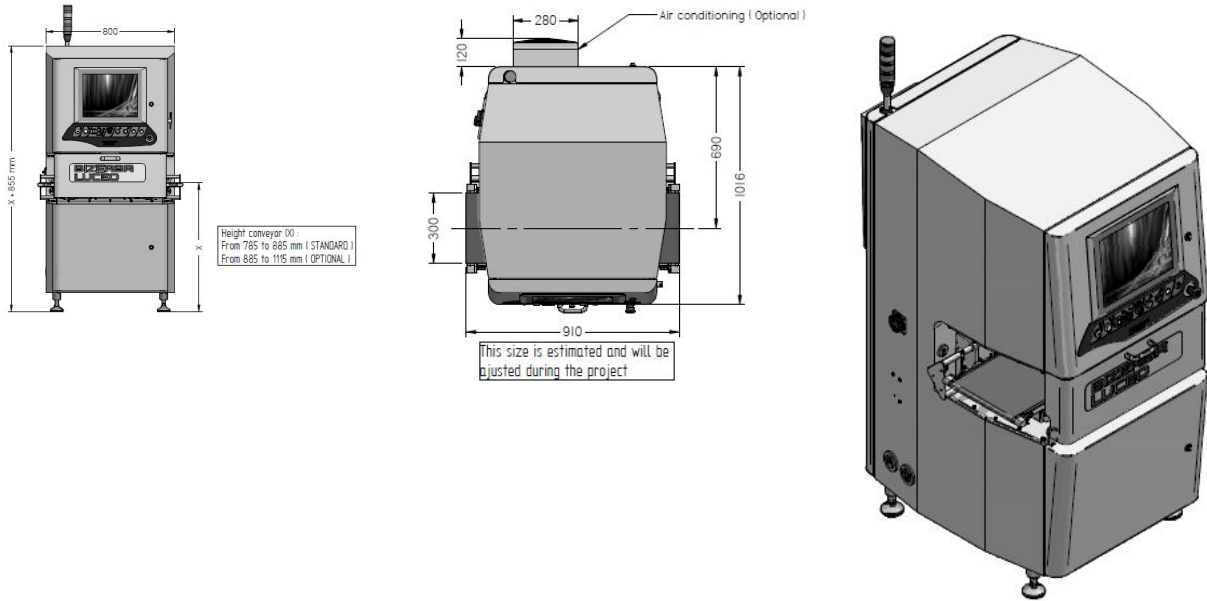

Bizerba SE & Co. KG
Wilhelm-Kraut-Straße 65
72336 Balingen

T +49 7433 12-0
fax: +49 7433 12-2696
marketing@bizerba.com

www.bizerba.com